

Typical Residential Driveway

See SUDAS Design Manuals for more info at: www.iowasudas.org

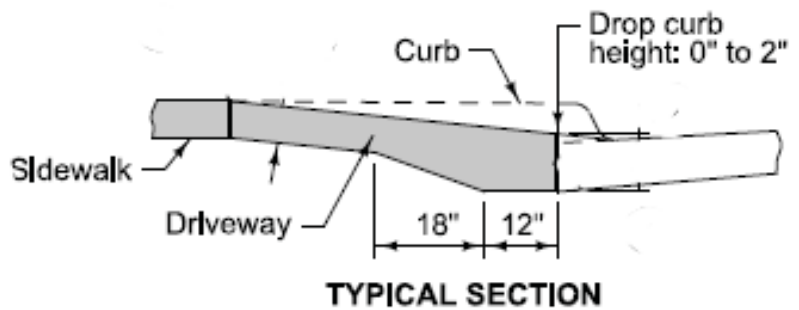
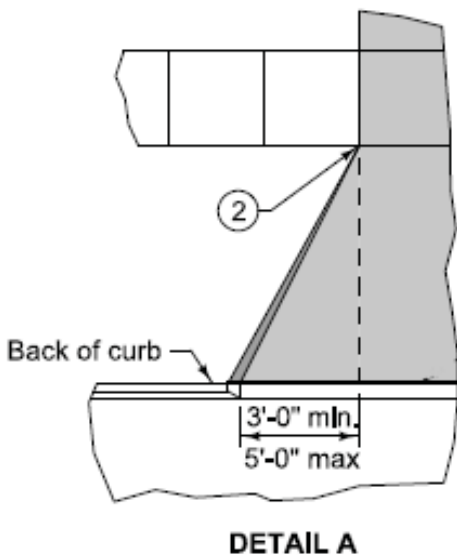
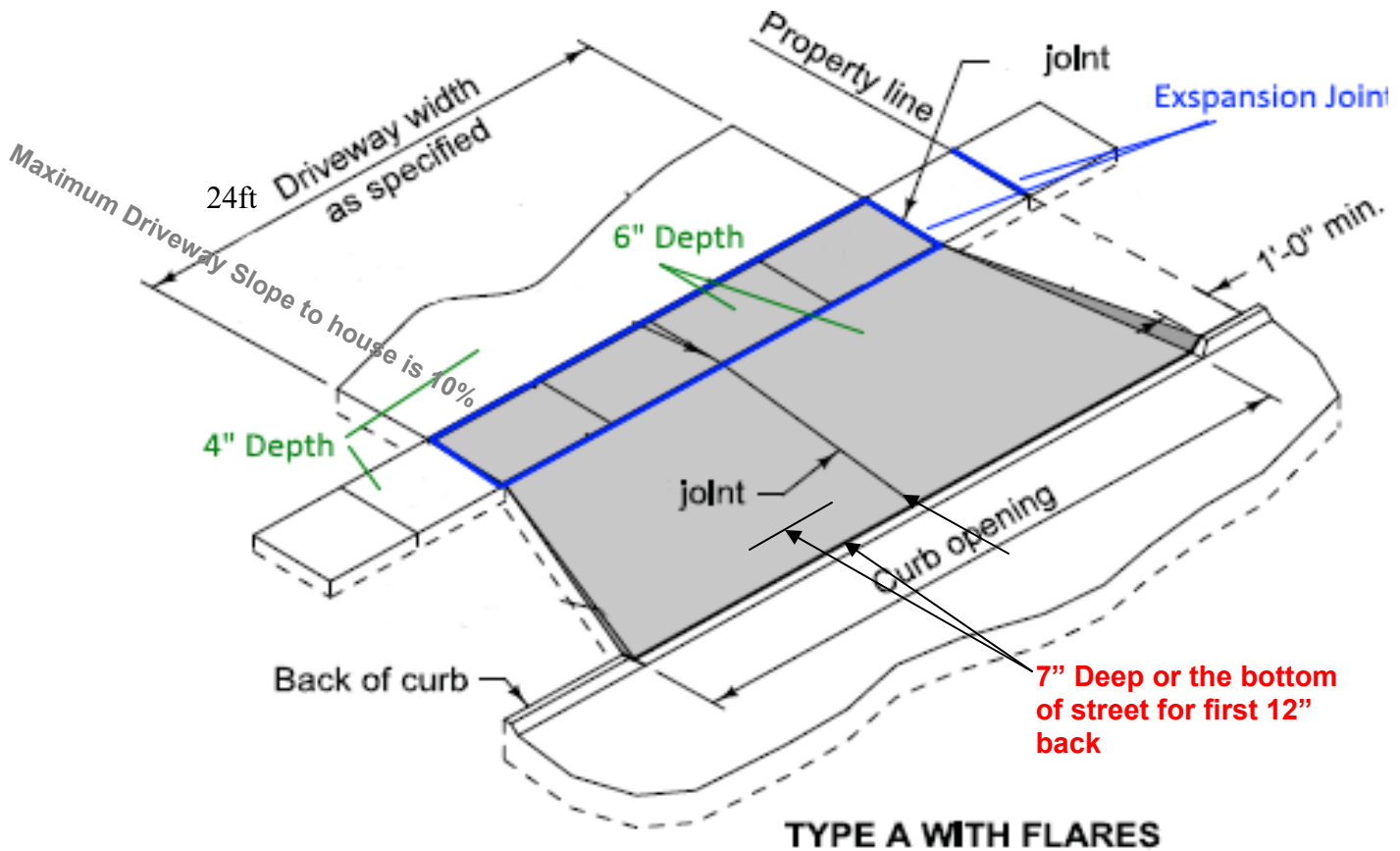

Driveway widths on residential areas are to be no more than 24ft wide. 30ft wide only if it's a major or minor arterial street.

The flares are not included in that 24ft and shall be 3ft to 5ft wide each side. So a curb cut will be between 30-34ft wide. (SUDAS Table 5I-4.01)

Figure 12A-2.03: Standard Sidewalk and Curb Ramp Elements

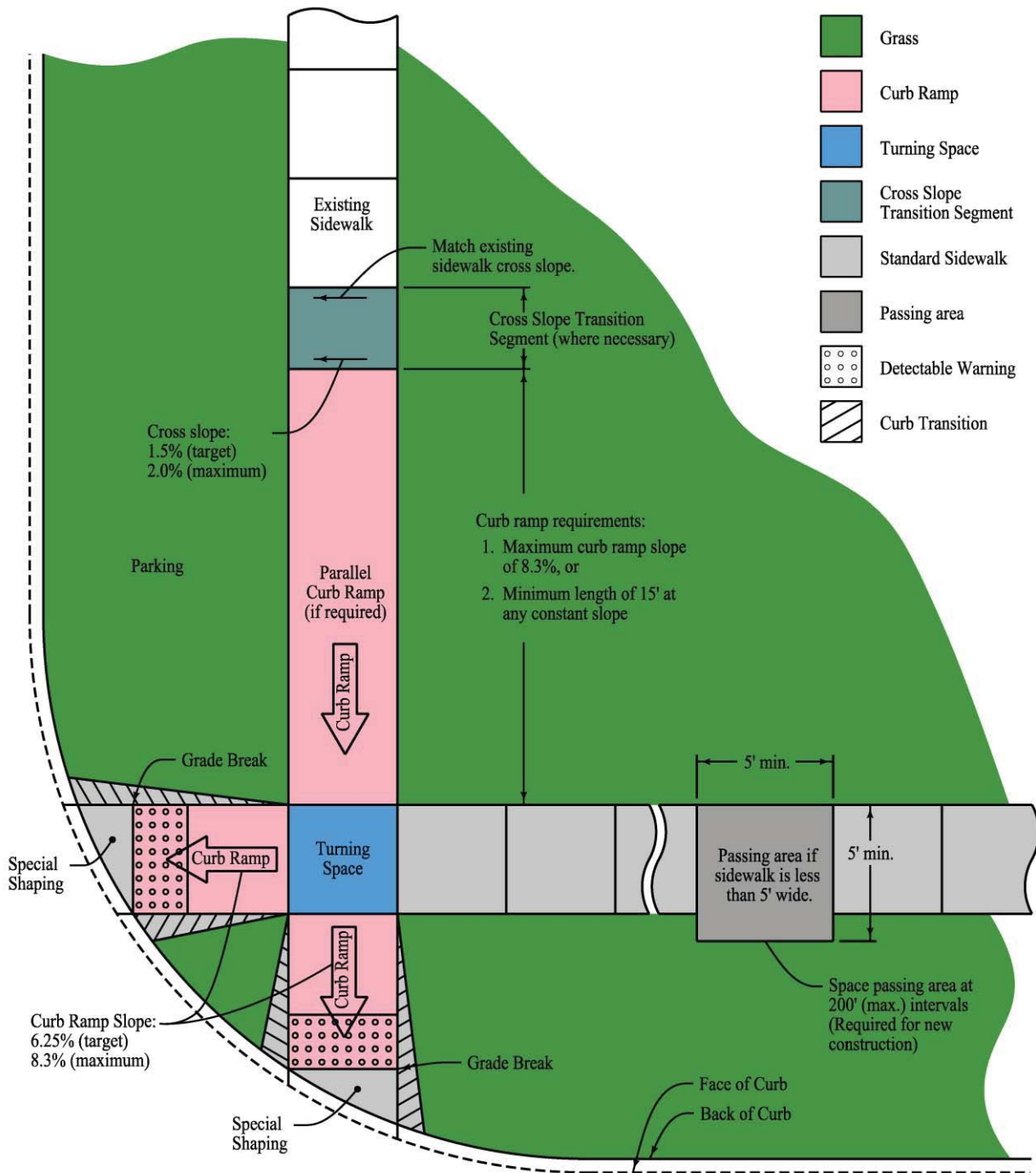

For more information see the SUDAS code or call the V&K building department @ 151 225-8000